

Section 11. T-1S, R-2W.

Prepared by the Salt Lake County Surveyors Office.

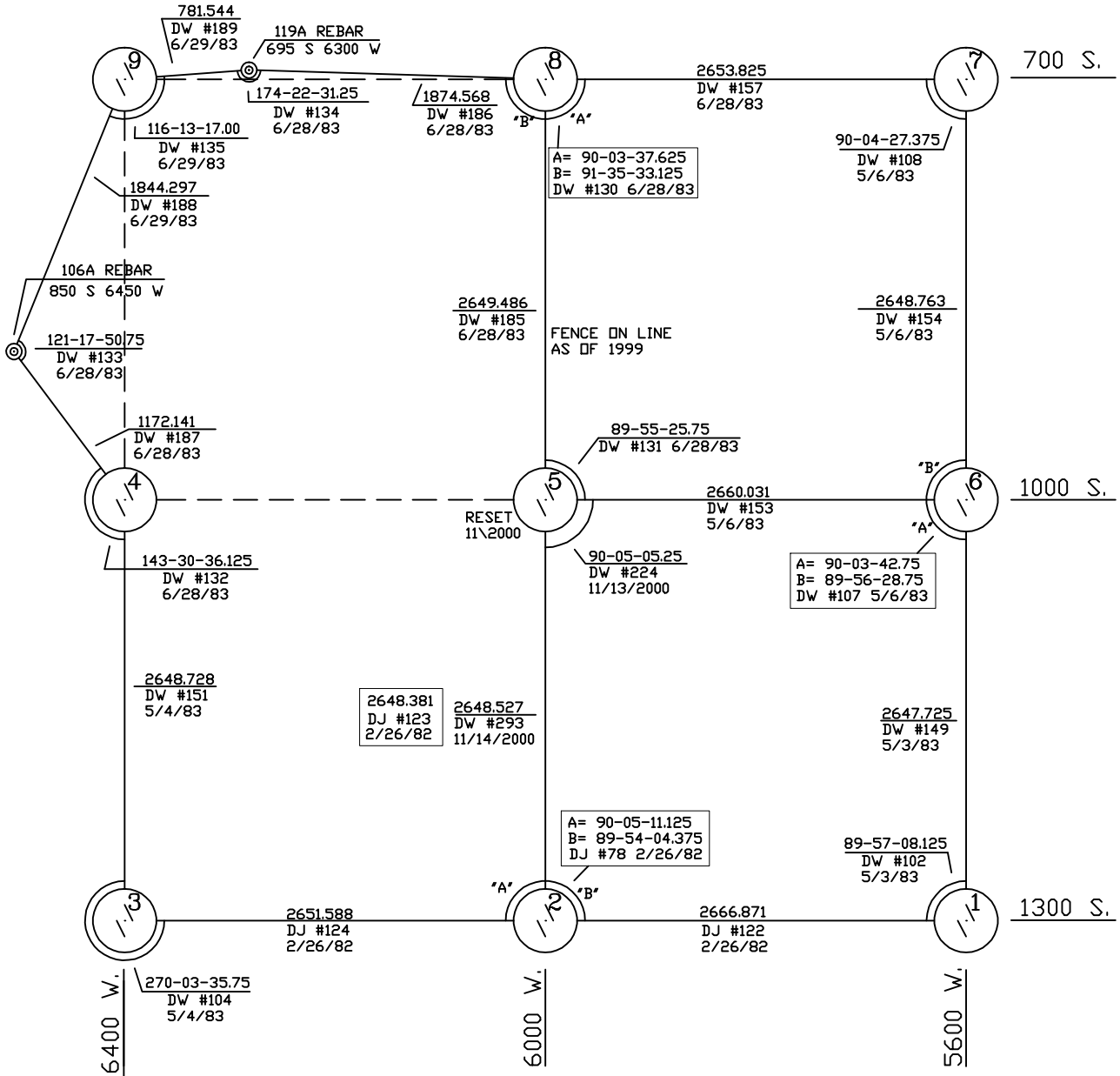

Revision	Date	Revision	Date
DRAWN BY: M. MURPHY	2/8/99	REVISED	11/2000
CHECKED BY: ANG.S= E.SHOSTED	2/26/99		
DIST.= E.SHOSTED	2/26/99		